

# MICROPLATE READER



## Instruction Manual



**Model : LMR-9602A**

Please read this manual carefully before using the instrument

**Labnics Equipment**

---

Please read the manual carefully before using the instrument. Some Precautions and Security Prompts

**LMR-9602A Microplate Reader** is specially used for vitro diagnosis. Please take the following precautions before using the instrument and strictly follow them.

1. Take protective measures before turning on the instrument by wearing gloves and other defending clothes as some samples may have some adverse effects.
2. Do not randomly discard the used sample. All samples, negative or positive controls, standards and waste should be treated as infectant.
3. Please do not refit the instrument.
4. The instrument wires should be connected properly to avoid electric shock, especially ground wires should be connected properly with the ground.
5. The AC power supply should be stabilized. Avoid using the same power supply with high-power equipments (especially break frequently) and avoid disturbing by strong electromagnetism.
6. To drag off the power wire, hold the plug itself instead of power wire.
7. If you find smog, peculiar smell or strange sound from the instrument, please cut off the power supply immediately and contact with the franchiser.
8. Cut off the power supply of instrument and cover it with dust proof cover after completing the detection process.
9. If you need to uninstall the cover for repair or other causes, you should first turn off the instrument and then cut off the power supply.
10. While working with the instrument, wear rubber gloves and wash your hands after completing your work to avoid any kind of infection.
11. Be careful while handling reagents or patient samples by hand or other body parts and in case your body wound comes in contact with the patient sample, wash immediately and consult doctor.
12. The instrument is a clinical detection equipment and has no taboos.

# Table of Content

CHAPTER	CONTENTS	Pg.No.
1.	INTRODUCTION	1
1.1	Characters	1
1.2	Main Functions	1
1.3	Cautions	1
2.	PRINCIPLE AND FEATURES	1
2.1	Working Principle	1
2.2	Components	1
2.3	System Schematics	2
3.	SPECIFICATIONS	2
3.1	Functions	2
3.2	Technical specifications	2
3.3	Work Condition	3
4.	PANEL	4
4.1	Front Panel	4
4.2	Back Panel	4
4.3	Preparation and Examinations	4
5.	PROGRAM	5
5.1	Programming Introduction	5
5.2	Programming Operation	5
6.	DETECTION	
6.1	Switch on the Instrument	14
6.2	Detection	14
7.	TIME SETTING	16
8.	MAINTENANCE	16
8.1	Lamp	16
8.2	Tray	16
8.3	Fuse	16
9.	TRANSPORTATION	16
10.	EQUIPMENT PACKING LIST	17
11.	QUALITY GUARANTEE	17
12.	WARNING	17
13.	SERVICE REPORT	18

## **CHAPTER 1 : INTRODUCTION:-**

### **1.1 CHARACTERS**

The LMR-9602A Microplate Reader is mainly used in clinical immunity-tests in the hospitals or epidemic preventing stations. It has unique features such as high sensitivity, high accuracy, high detection speed and smooth running of operation etc. The instrument has a dedicated keyboard that enables you to rapidly change functions and set parameters. Display is a liquid crystal type with alphanumeric and graphic options. Setting and detecting operations are easy.

### **1.2 Main Functions**

- (1) The instrument is mostly used for the detections of enzymatic plate and cultivated plate in enzymatic tests of hospitals or other departments.
- (2) Corresponding detections for microanalysis in chemistry or biochemistry.

### **1.3 Cautions**

The instrument had been strictly inspected and tested before leaving the factory, so it doesn't need assembly and testing before detection and you should be able to operate it just by following the instructions of the manual.

- Be careful not to spill liquid on the control panel.
- When you place samples or containers on the flask holders or spring rack, be sure about the weight balanced. Wrong balanced weight may cause damage to motor or shaking mechanism and may cause noise or vibration.

## **CHAPTER 2 : PRINCIPLE AND FEATURES:-**

### **2.1 Working Principle**

This instrument works on the principle of "Photoelectric Colorimetry". It can detect the absorbance of detecting sample and standard liquid. Also it can analyze and calculate the absorbance value and finally produce the values or the condition for detecting sample in the liquid.

### **2.2 Components**

The instrument has two main components: "the mainframe" and "the printer". The mainframe composed of optic system, 8-channel detection system, singlechip system and enzymatic plate driving system.

## 2.3 System Schematics

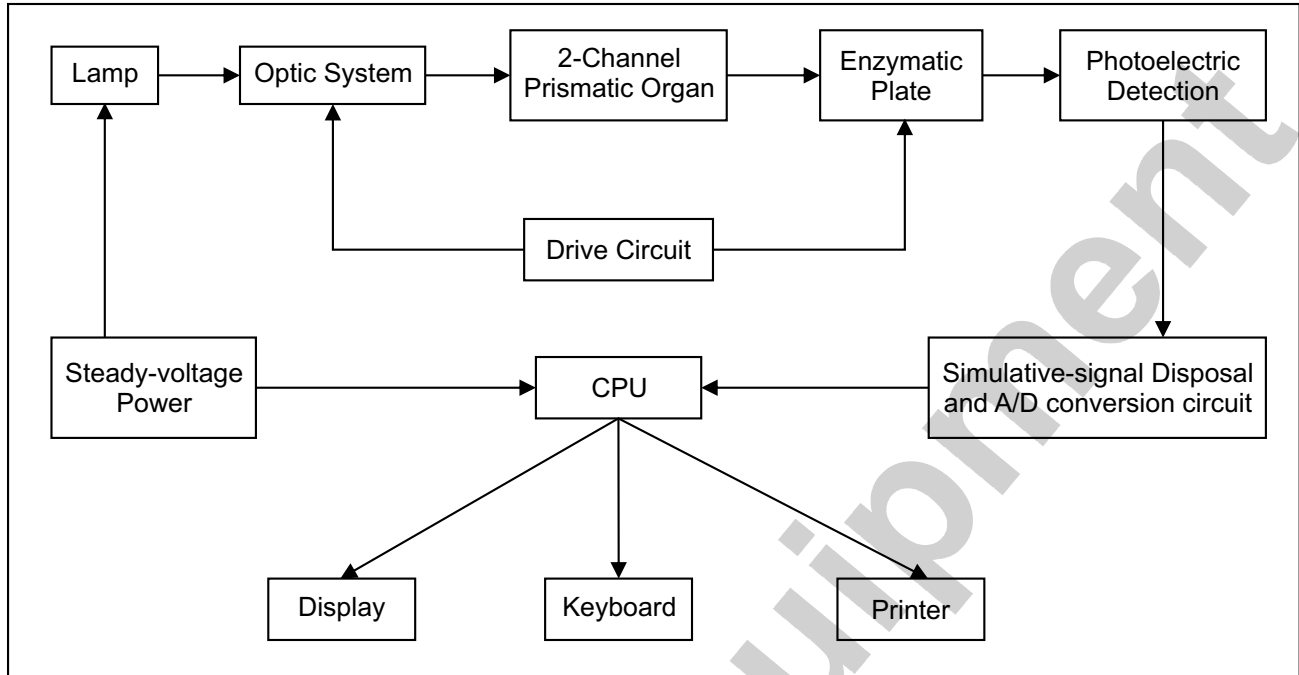

Fig. 1 : System Schematics

## CHAPTER 3 : SPECIFICATIONS

### 3.1 Functions

- (1) Detect absorbance as well as used in qualitative and quantitative detection.
- (2) It can store maximum 30 programmes in general use and display programs parameters on LCD.
- (3) The instrument can automatically select filters for different items.
- (4) On starting the instrument, it will first undergo auto-check process by checking initial settings and if there is some error, the corresponding prompt will appear on the screen.
- (5) The instrument has printing function.

### 3.2 Technical Specifications:

- (1) The instrument has 2 filters when leaving factory: 450nm and 492nm
- (2) Characteristics of the filters

Accuracy of wave (nm)	Half-width (nm)
±3.0	12

Table 1: Characters of the Filters

(3) Detection range of instrument is from 0.1A to 3.0A. The errors of absorbance are as follow.

Absorbance (A)	Accuracy Error
0.1--1.0	±1.0% or ±0.01A
>1.0--2.0	±2.0% or ±0.02A
>2.0--3.0	±10.0% or ±0.10A

Table 2: Absorbance Accuracy

(4)

Absorbance (A)	Error (%)
0.1--1.0	±1.25
>1.0--2.0	±2.0
>2.0--3.0	±8.0

Table 3: Linearity of the Instrument

- (5) Repeatability : ≤1.0%
- (6) Stability : ≤±0.005A/10min
- (7) Detection modes : single wavelength
- (8) Display : 192×64 pixels LCD screen
- (9) Print : Inner stylus printer
- (10) Data Link : RS232 serial port
- (11) Output : Absorbance, qualitative judgment, value of P/CO, concentration, judgment of normal value and quality control value
- (12) Dimensions : 370 × 245 × 170 mm
- (13) Weight : 7Kg

### 3.3 Work Conditions

- (1) Environmental temperature: 10 ~ 30 C ;
- (2) Relative humidity: 70%;
- (3) Keep away from strongly electromagnetic field;
- (4) Avoid direct irradiation from strong light;
- (5) The work place must be dust-proof and shake-proof. There should be no caustic gas such as hydrochloric acid in the air;
- (6) Power supply: 220 x (1±10%) V, 50 x (1±2%) Hz;
- (7) Power supply must be grounded perfectly.

## CHAPTER 4 : PANEL

### 4.1 Front Panel

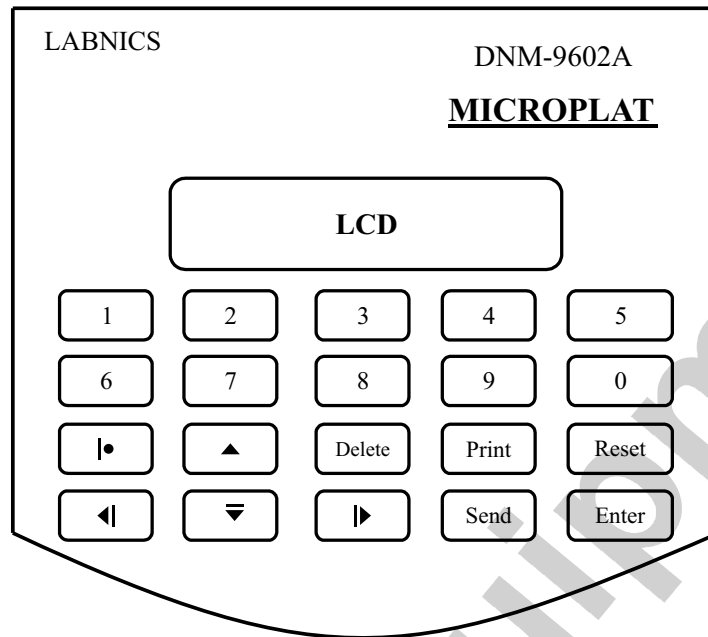

Fig. 2: Front Panel

### 4.2 Back Panel

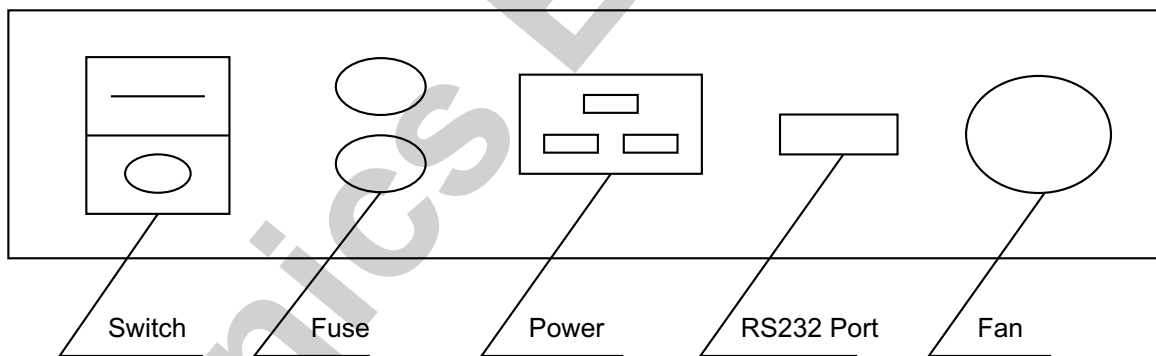

Fig. 3 : Back Panel

### 4.3 Preparation and Examination

First examine the instrument whether having scatches such as distortion or cracks due to inappropriate transportation and storage. If there is no damage found, you can plug into the electric socket and switch on power. Then the main menu (Fig. 4) appears on the display.

**Note:** Before beginning the detection, you must wait 10 minutes for a complete warming up from the time when the instrument was switched on.

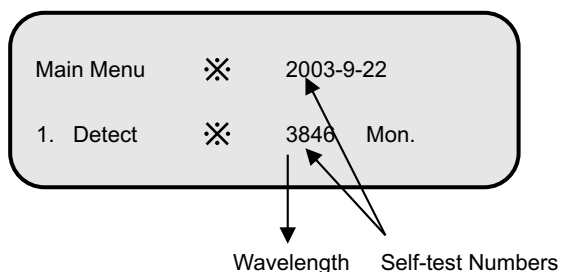

Fig. 4 : Main Menu

## CHAPTER 5 : PROGRAMMING

Before beginning detection, you should first decide the order of programs according to the needs for your convenience, order of program numbers should be based on the following principles:

- (1) Put the most commonly used detection items in the front and arrange combined items together .
- (2) The program number is from 00 to 29.

### 5.1 Programming Introduction

- 5.1.1 There is a default function in each menu. If the default function meets actual need, please press **Enter** key to go to sub menu. It is the instrument default function if the cursor stays here or the symbol of ● is in front of the item.
- 5.1.2 There are **Return** and **Continue** functions in each menu. If **Return** is selected, the instrument will return to the superior menu; if **Continue** is selected, the instrument will go to sub menu.
- 5.1.3 In case of any input or selection mistake, you can always go back by using the cursor or pressing **Delete** key on the panel.
- 5.1.4 You can freely set blank, negative, positive and quality control wells on the enzymatic plate when you do qualitative detection. And you can set 1 or 2 blank, negative and positive wells. But the number of quality control wells must be 2. When you do quantitative detection, you should set standard wells from small row to large row.
- 5.1.5 In the process of programming, if you want to stop programming and return to the main menu, please press **Reset** key.

### 5.2 Programming Operation

#### 5.2.1 Input Program Number and Name

If you want to program, select 2 in the main menu and then the following menu will appear on the display.

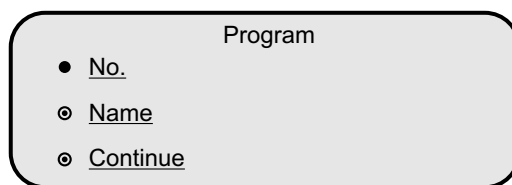

Fig. 5: Program Menu

### Explanations:

1. When the symbol in front of **No.** is ●, please press numerical numbers to input program number 00-29 and then press **Enter** key;
2. After the symbol in front of **Name** becomes ●, press **Enter** key. Then press ▲ or ▼ to select the first character. Press ▶ after the needed letter or number has been selected. Then the cursor shifts to the second character. Press ▲ or ▼ to select the second letter or number. Redo above operations till all letters and numbers of the program name needed have been input. Then press **Enter** key to confirm;
3. At this time, the symbol of ● is in front of **Continue**. If you want to continue programming, press **Enter** key to confirm. Then the interface of selecting wavelength (Fig. 6) appears. If you want to return to the main menu, press **Reset** key.

### 5.2.2 Select Wavelength



Fig. 6: Wavelength Selecting

### Explanations:

1. With the consideration that working wavelength of most items is 450nm, the default wavelength is 450nm. If the default value is consistent with the reagent specification, press **Enter** key directly and go to the sub menu (Fig. 7);
2. If the wavelength needed is 492nm, press ▲ or ▼ to make the symbol in front of **Wavelength** be ●. Then press **Enter** key and press ▲ or ▼ to select the wavelength. Finally press **Enter** key to confirm;
3. At this time, the symbol of ● is in front of **Continue**. If you want to continue programming, press **Enter** key to confirm. Then the interface of selecting detection mode (Fig. 7) appears. If you want to return to the main menu, press **Reset** key; if you want to return to the superior menu, press ▼ and **Enter** key;
4. The knob beside the instrument points to the wavelength selected.

### 5.2.3 Detection Mode

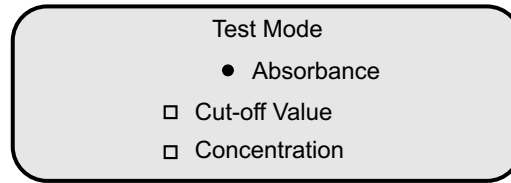

Fig. 7: Detection Mode

#### Explanations:

1. The default detection mode of the instrument is absorbance detection. If you just want to obtain absorbance of the sample without any analysis and calculation, select this mode. At this time press **Enter** key to go to sub menu (see paragraph 5.2.6);
2. When it is required to judge the negative and positive critical values (cut-off values) of the sample, you should select the detection mode of **Cut-off Value**. Press **▼** to make the symbol in front of Cut-off Value become **●**. Then press **Enter** key to enter the interface of cut-off value detection mode (see 5.2.4);
3. When it is required to detect concentration of the under detection sample, you should select the concentration detection mode on above figure. Press **▼** to make the symbol in front of **Concentration** become **●**. Then press **Enter** key to enter the interface of concentration detection mode (see 5.2.5);
4. If you want to return to the main menu, press **Reset** key; if you want to return to the superior menu, press **▼** till the symbol in front of **Return** becomes **●** and then press key.

### 5.2.4 Cut-off Detection Mode

#### 5.2.4.1 Formula for calculation

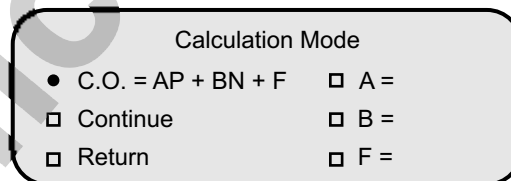

Fig. 8: Calculation Mode

#### Explanations:

1. The definitions of letters in above formula are as follows:  
**C.O.:** absorbance of the under-detection sample;  
**N:** average absorbance of negative-control wells;  
**P:** average absorbance of positive-control wells;  
**A, B, F:** parameters to be input?according to reagent Specification).

- When a formula is selected, the right-hand side of the screen displays: **A=** , **B=** , **F=** . At this time you should input values according to the reagent specification, and then press **Enter** key to confirm. First input the value of A and press **Enter** key to confirm. Then the symbol in front of **B** change to ●. Input the value of B and press **Enter** key to confirm. Also the symbol in front of F change to ●. Then input the value of F and press **Enter** key to confirm.
- When the cursor stays on **Continue**, press **Enter** key to go to sub menu (Fig. 9). If you want to return to the main menu, press **Reset** key; if you want to return to the superior menu, press ▼ till the symbol in front of **Return** becomes ● and then press **Enter** key.

#### 5.2.4.2 Formula for calculation

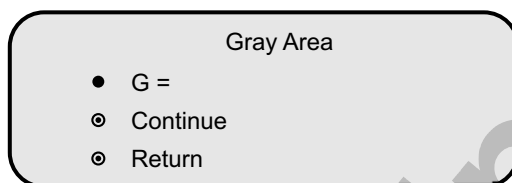

Fig. 9 : Gray Area

#### Explanations:

- The definition of the letter in above formula is as follows:  
**G**: the gray area value. Use the value of  $1 \pm G$  to examine whether the results are in the gray area;
- After you enter the value, the cursor will stay on **Continue**. Press **Enter** key to go to sub menu (Fig. 10). If you want to return to the main menu, press **Reset** key; if you want to return to the superior menu, press ▼ till the symbol in front of **Return** becomes ● and then press **Enter** key.

#### 5.2.4.3 Input Limited value

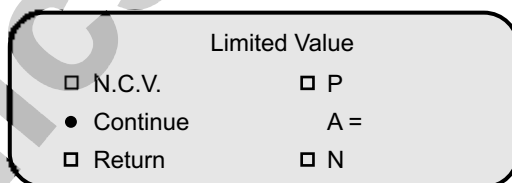

Fig. 10: Limited Value Input

#### Explanations:

- If the reagent specification prescribes that you should calculate according to the input value when the negative-control value is less than the input value (for example: 0.05), please select **N** (It is the abbreviation for negative.) and input the right value. If the reagent specification prescribes that you should calculate according to the input value when the negative-control value is more than the input value (for example: 1.20), please select **P** (It represents positive.) and input the right value. **A** represents the cut-off value. **N.C.V.** is the abbreviation for Cut-off Value;

- If the reagent specification does not prescribe, directly press **Enter** key to go to the interface of quality judgment (Fig. 11). If you want to return to the main menu, press **Reset** key; if you want to return to the superior menu, press  $\blacktriangledown$  till the symbol in front of **Return** becomes  $\bullet$  and then press **Enter** key.

#### 5.2.4.4 Quality judgment

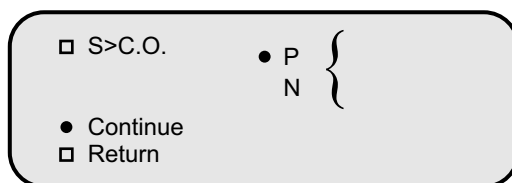

Fig. 11: Quality Judgment (1)

#### Explanations:

- There are two methods to judge quality. The first method suits the items: if the value of the unchecked sample is not less than the cut-off value, it is positive (+); contrarily negative (-). The second method suits the items: if the value of the unchecked sample is not less than cut-off value, it is negative (-); contrarily positive (+);
- The first type is set as default. If it is equal to the demand, press **Enter** key to go to the sub menu (Fig. 12). **C.O.** is the abbreviation for Cut-off value;
- If the reagent prescribes the second method, press  $\blacktriangle$  to make the symbol in front of **S** become  $\bullet$  and press **Enter** key. Then select the second judgment method by the key of  $\blacktriangledown$  and press **Enter** key to confirm. Press **Enter** key again to enter the interface of invalidity judgment (Fig. 12).

#### 5.2.4.5 Invalidity judgment

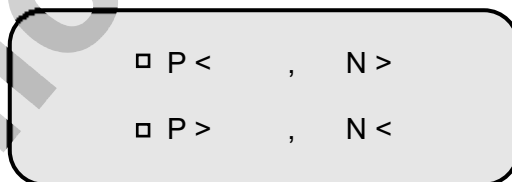

Fig. 12: Invalidity Judgment

#### Explanations:

- Reagent specifications of some detection items prescribe the validity judgment of the absorbance for positive-control value and negative-control value to ensure validity of detection results. Under this circumstance, please input the prescribed value as required by reagent specification;
- If the reagent specification has no requirement, you can press **Enter** key to go to the sub menu (Fig. 13);

3. If the reagent specification has some requirements, press **▲** to select the needed item and press **Enter** key to confirm. Then press numerical keys to input the positive-control value and then press **Enter** key to confirm. Press numerical keys to input the negative-control value and press **Enter** key to confirm;
4. At this time, the symbol in front to Continue becomes ●. If you want to continue to program, press **Enter** key to enter the interface of wells setting (Fig. 13). If you want to return to the main menu, press **Reset** key; if you want to return to the superior menu, press **▼** till the symbol in front of Return becomes ● and then press **Enter** key.

#### 5.2.4.6 Set wells

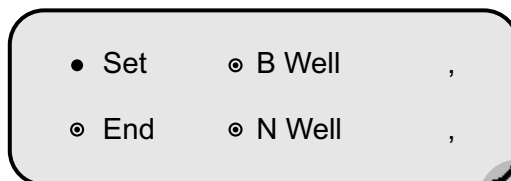

Fig. 13 : Well Setting (1)

#### Explanations:

1. The definitions of letters in above figure are as follows:  
**B Well** : blank well;  
**N Well** : negative well;  
**P Well** : positive well;  
**Q Well** : quality control well.
2. The instrument allows that each comparison well be set at any place on the plate. The input symbol of the well place must be consistent with the sample place on the enzymatic plate;
3. Press **▲**, **▼** or **▶** to select places of wells. Press **▶** to select the row number (for example: C, D) and press **▼** to select the column number (1-12);
4. The following are the specific setting steps. When the symbol in front of B Well becomes ●, select place of blank well by the symbols **▲**, **▼** and **▶**. Press **▶** to select the row number and press **▼** to select the column number. Then press **Enter** key to confirm. When the symbol in front of N Well becomes ●, select places of negative wells and press **Enter** key to confirm. When the symbol in front of P Well becomes ●, select places of positive wells and press **Enter** key to confirm;
5. You can select the quality control well based on your demands. If you do not need quality control, continuously press **Enter** key till the symbol in front of End becomes ●, and then enter the interface of saving program (Fig. 14).

#### 5.2.4.7 Finish programming

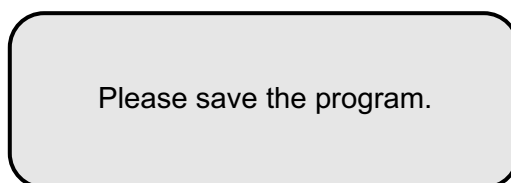

Fig. 14: Finish Programming

### Explanations:

When the screen displays above figure, press **Enter** key on the panel to store the program information in the instrument for future use. Then the instrument automatically returns to the main menu.

## 5.2.5 Concentration Detection Mode

If the detection mode is concentration, the next step is selecting a calculation mode.

### 5.2.5.1 Select a calculation mode

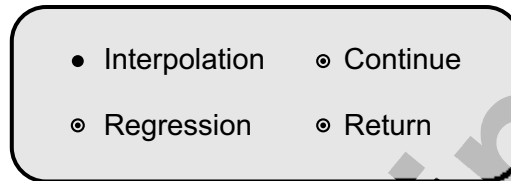

Fig. 15: Calculation Mode

### Explanations:

1. How to select the calculation mode is decided by the reagent specification;
2. Press  $\blacktriangle$  or  $\blacktriangledown$  to select a mode. If a mode is selected, the symbol in front of the mode becomes  $\bullet$ . Then press **Enter** key. The cursor stays on "A= ". Please input the dilution coefficient required by the reagent specification, and press **Enter** key to confirm your input. If the reagent is not diluted, please input **1** and press **Enter** key to confirm;
3. The symbol in front of Continue becomes  $\bullet$ . If you want to continue programming, press **Enter** key to confirm. Then enter the interface of wells setting. If you want to return to the main menu, press **Reset** key; if you want to return to the superior menu, press  $\blacktriangledown$  till the symbol in front of Return becomes  $\bullet$  and then press **Enter** key.

### 5.2.5.2 Set wells

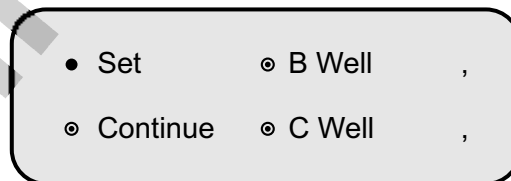

Fig. 16: Wells Setting (2)

### Explanations:

1. The definitions of letters in above figure are as follows:  
**B Well** : blank well;  
**C Well** : standard well;  
**Q Well** : quality control well

2. The instrument prescribes **C01** is the blank well when the detection mode is concentration mode;
3. The amount of standard wells is prescribed by the reagent specification (the largest amount is six);
4. When the symbol in front of **Set** is ●, press **Enter** key. Then the cursor shifts to **B Well**. Press ▼ to select the well of **C01**, and press **Enter** key to make the cursor shift to **C Well**. Then press ▼ to select **C02** as position of the first standard well and press **Enter** key to confirm. The next step is pressing ▶ to select positions and number of the standard wells till all wells required have been selected and then press **Enter** key to confirm. Shift the cursor to **Q Well** to select quality control well. If the quality control is not required, you should continuous press **Enter** key;

**Note: It is prescribed that the blank well must be set at C01 and the standard wells must be set in the direction of C01, C02, C03 and C04.**

5. The symbol in front of Continue becomes ●. If you want to continue programming, press **Enter** key to confirm. Then enter the interface of standard values setting. If you want to return to the main menu, press **Reset** key; if you want to return to the superior menu, press ▼ till the symbol in front of Return becomes ● and then press **Enter** key.

#### 5.2.5.3 Set standard values

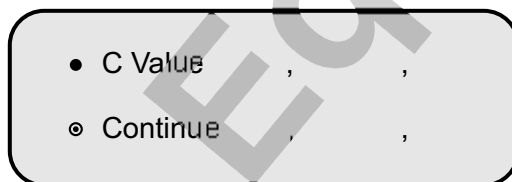

Fig. 17: Standard Values Setting

#### Explanations:

1. Input the standard concentrations as required by the reagent specification in the order from small values to large values. In above figure, **C Value** means standard value. Press **Enter** key to confirm after the value is input (The amount of concentrations input should be equal to the amount of the standard wells set before);

**Caution: When the detection method is logarithm method, you can't input the first concentration value if it is zero, otherwise the detection results will contain errors.**

2. The symbol in front of **Continue** becomes ●. If you want to continue programming, press **Enter** key to confirm. Then enter the interface of normal values setting. If you want to return to the main menu, press **Reset** key; if you want to return to the superior menu, press ▼ till the symbol in front of **Return** becomes ● and then press **Enter** key.

#### 5.2.5.4 Set normal values



Fig. 18: Normal Values Setting

#### Explanations:

1. Nor. is the abbreviation for normal;
2. Input the lower limit normal value and press Enter key to confirm. Then input the upper limit normal value and press Enter key to confirm. After that, the instrument enters the interface of saving program (Fig. 14).

**5.2.5.5** The sub menu is finishing programming menu. Operations of the menu are completely the same as the cut-off detection mode (see 5.2.4.7).

#### 5.2.6 Absorbance Detection Mode

**5.2.6.1** When the absorbance detection mode is selected, the instrument will directly display the interface of wells setting.

**5.2.6.2** Set wells



Fig. 19: Wells Setting (3)

#### Explanations:

1. If you want to print the original absorbance, please press **Enter** key continuously to end programming (without inputting the blank wells);
2. If you want to print the actual absorbance (deducting the blank value), please input the symbol of blank wells (1~2). In above figure, **B Well** means blank well.

**5.2.6.3** Programming is finished. Operations of the menu are completely the same as the former one. (see 5.2.4.7).

## CHAPTER 6 : DETECTION

This instrument can be used for clinical tests after being programmed.

To ensure veracity of detection results, please note the following items:

1. Wells of blank, negative control, positive control or standards on the board should be consistent with program.
2. If reagent has been changed, you should use the new negative control, positive control and standards to calibrate.
3. Strictly accord to the reagent specification to detect.
4. Create indoor quality control system and assure the quality state of real detection in time by detecting the quality control samples.

You must turn the manually selecting knob to the wavelength needed. The following picture (Fig. 20) shows the position of the knob.

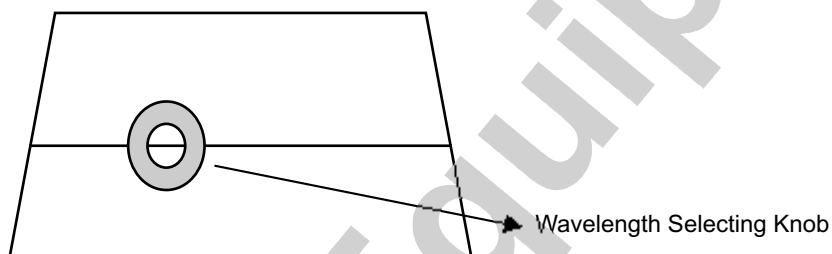

Fig. 20 Side of the Instrument

### 6.1 Switch on the Instrument

Switch the instrument on and then it will start auto-checking first. If the instrument passes auto-checking, the screen will display the main menu. At that time, you should not start the detection immediately. Please wait 10 minutes for a complete warming up before you begin the detection;

### 6.2 Detection

6.2.1 When the instrument displays the main menu, press numeric key 1 on the panel to select a detection function. The following picture shows the detection interface.

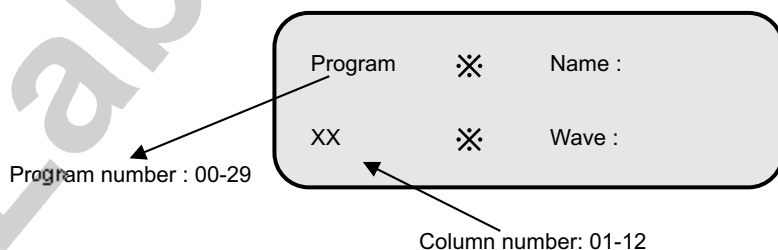

Fig. 21 Detection Interface (1)

### 6.2.2 Select a program

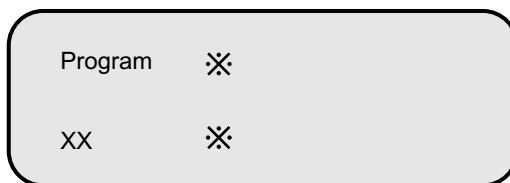

Fig. 22 Detection Interface (2)

When entering the detection interface, the cursor will stay on the program number. At this time, press  $\blacktriangle$  or  $\blacktriangledown$  to select different program numbers and press  $\blacktriangleright$  to see content of the program. If there is no error, press **Enter** key to confirm. At this time, the cursor stays on the column number. Press  $\blacktriangle$  and  $\blacktriangledown$  to confirm the column number. Then press **Enter** key to start detection.

### 6.2.3 When the detection is completed, the results will display on the screen.

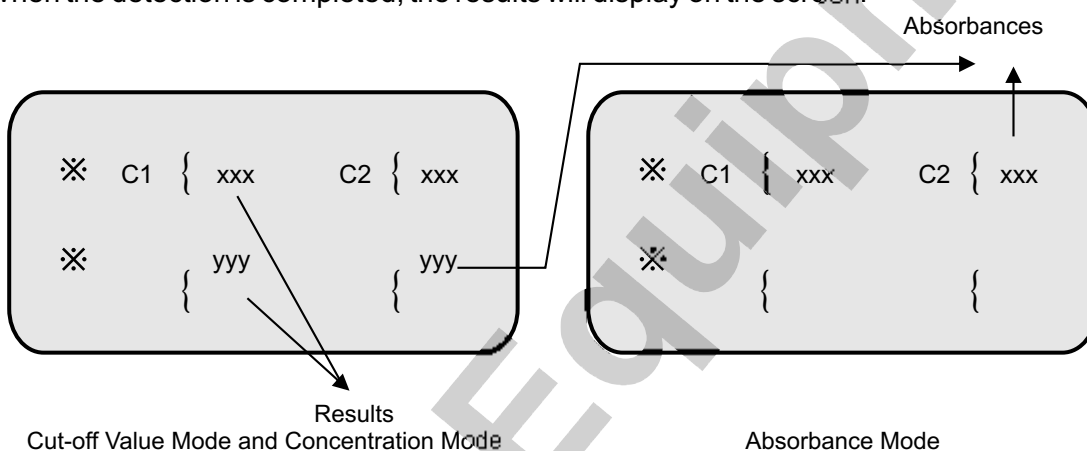

Fig. 23 Results Interface

If the detection mode is cut-off detection mode, the results are the value of P/CO and judgment (+, -) by the cut-off value. And if the detection mode is concentration mode, the results are concentration and judgment (H, L) by normal values.

### 6.2.4 If the results need to be printed, press **Print** key (print all contents on the display). After you press **Print**, the inner printer of the instrument prints all the results for one time.

**Note:** 1. If the detecting result of concentration is 99999, it means the concentration of the sample is beyond the linear range (the standard concentration range prescribed by the reagent specification). You should dilute the sample and conduct the detection again.  
2. In the detection report, NCAV means average negative-comparison absorbance; PCAV means average positive-comparison absorbance.

### 6.2.5 When all the work above is finished, you can take the enzymatic board out, and press **Enter** key. Then the instrument will display contents of the program again. If you still want to continue detection of the item, replace a new enzymatic board and repeat the operating steps starting from step 6.2.2

### 6.2.6 If you want to detect other items, press **Enter** key and then press ? to select a new program. Put on the enzymatic plate and press **Enter** key to begin a new detection.

### 6.2.7 After all detection items are finished, press **Reset** key on the panel. It will come back to the main menu. Then you can turn off the power, and pull out the plug.

## CHAPTER 7 : TIME SETTING

Press numerical key 3 in the main menu to enter the interface of time setting (Fig. 24). In the following interface, you should input a number from 01 to 07 on the third line, the number means Monday to Sunday. For example, if you want to set Thursday, please input 04. After you input the current date and time, information that prompts you the programming is over appears. Press **Enter** key to confirm. After 4 seconds for the instrument saving the time set and then return to the main menu automatically. The setting of time is over.

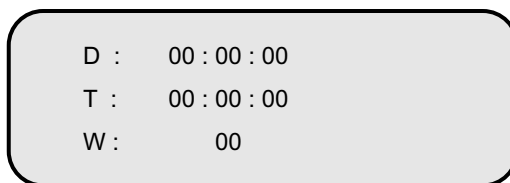

Fig. 24 Time Setting

## CHAPTER 8 : MAINTENANCE

The instrument only needs cleaning in normal use. But the following assemblies may fail or malfunction after a long time of use. You must maintain them under the guidance of the specialist.

### 8.1 Lamp

The instrument will prompt you if the light lamp fails. At that time, you should open the lid of the instrument and examine it. If you confirm that the lamp is broken, please replace it with a lamp of the same standard. If something is wrong with the power, you should repair it.

### 8.2 Tray

When there is something wrong with the tray (e.g. it can't pass through the instrument), there are some possible reasons: down lead of the step-motor is not perfectly connected; synchronous strap is loose or doffed; moving parts shift or get blocked etc. Please search for the cause and fix the malfunction.

### 8.3 Fuse

If the fuse burns out, you must cut off the power supply at first, and then replace the fuse with one of the same standard. You must replace the fuse under the guidance of the specialist.

## CHAPTER 9 : TRANSPORTATION

1. Range of Environmental Temperature : -20C ~ +55C
2. Relative Humidity of Environment : ≤93%
3. Range of Atmosphere Pressure : 500hpa~1060hpa.

## CHAPTER 10 : PACKING LIST

Name	Number
(1) LMR-9602A Microplate Reader	1
(2) User's manual	1
(3) Product certificate	1
(4) Users Checking and Accepting sheet	1
(5) Accessories	
a) Wire for power supply	1
b) Fuse $\phi 5 \times 20$ 2A	2

## CHAPTER 11. QUALITY GUARANTEE

We will repair or replace the instrument or accessories free of cost if there is any problem with the instrument, provided that you have complied with the instructions of this user's manual, and it is within one year from the date of purchase. You will be charged if you have not followed this user's manual or you have disassembled the instrument without authorization. Our company will answer maintenance related questions for the instrument even after the one-year warranty period.

## CHAPTER 12. WARNING

- (1) The power wire should be earthed properly.
- (2) Filter must be changed by the professional.

